

Operating Instructions – Holland LocknLoad Wheel Chock

Loading Procedure

- 1. Remove from storage pan**
Rotate red / green pedal to unlock. Pull up and away. Rotate ramp.

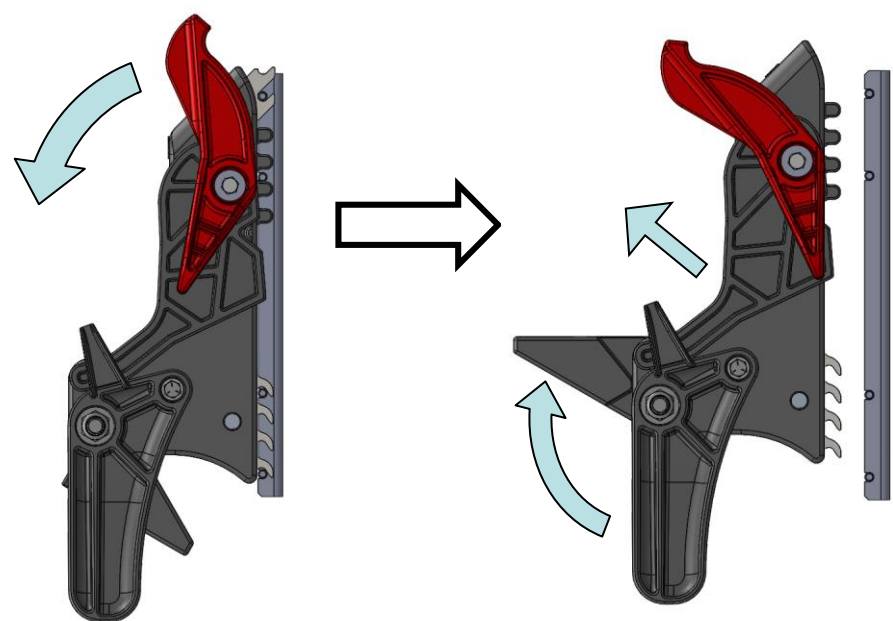

2. Secure to grating

Position ramp close to tire as shown with gap to tire at 3/4" or less. Make sure teeth are set in grating and chock is flat and level with grating. Lock the red / green pedal. Tug handle to ensure chock is locked. If not, unlock and repeat installation.

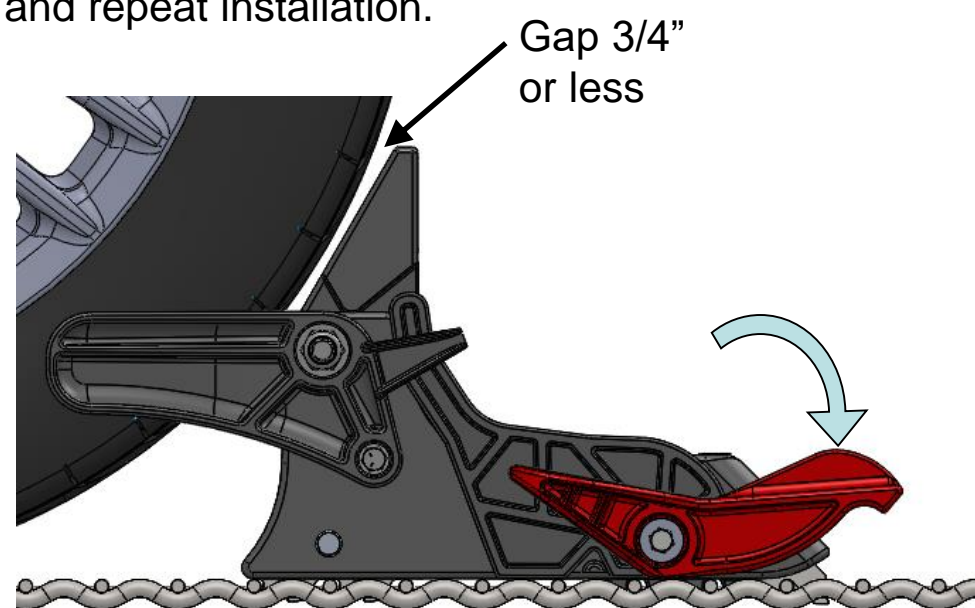

3. Verify Engagement

Once the chock is locked into the grating, look for a gap between the Chock Removal Assist Lever, and the Lateral Paddle. If the gap is there (white marker is showing), then the chock has been correctly engaged into the grating.

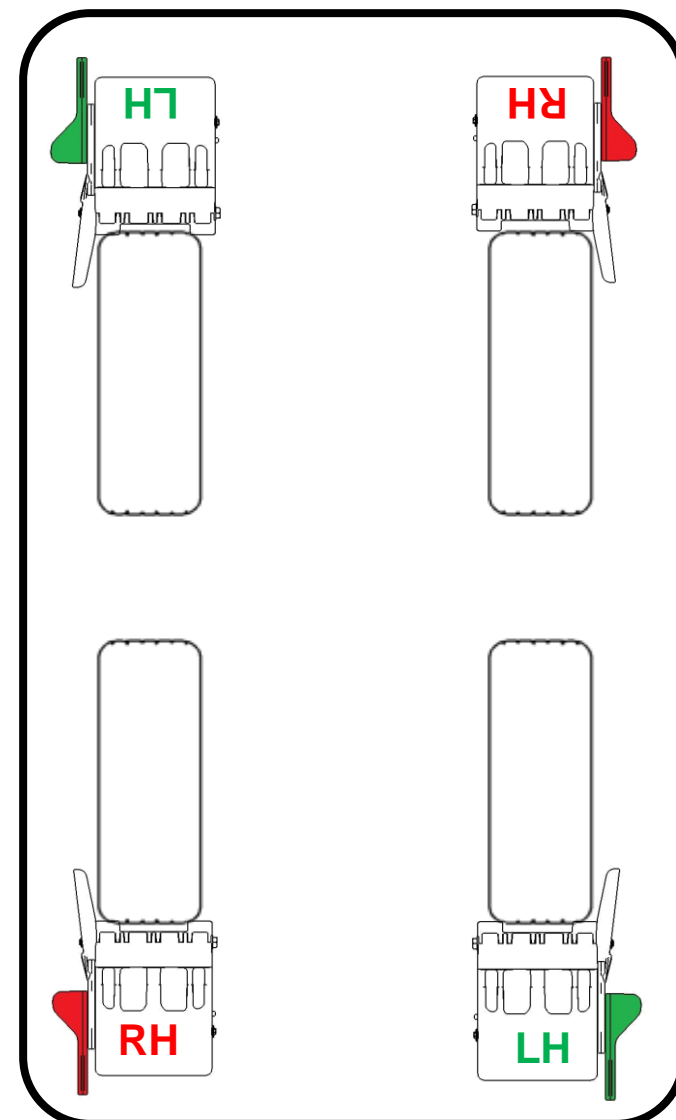
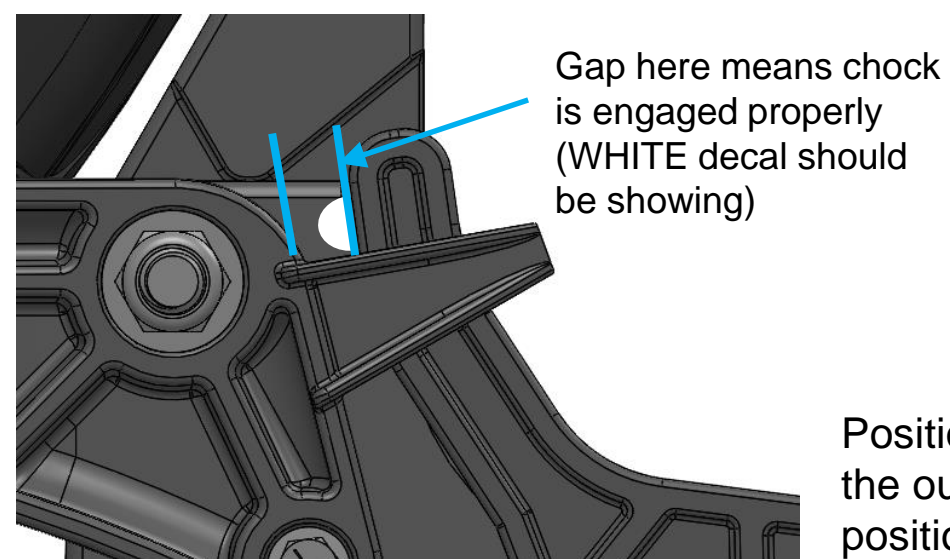

Standard Vehicle Layout

Position chock outboard of the vehicle such that the lateral paddle is to the outside of the tire. Make sure lateral paddle has a gap of 3/4" or less to the tire sidewall.

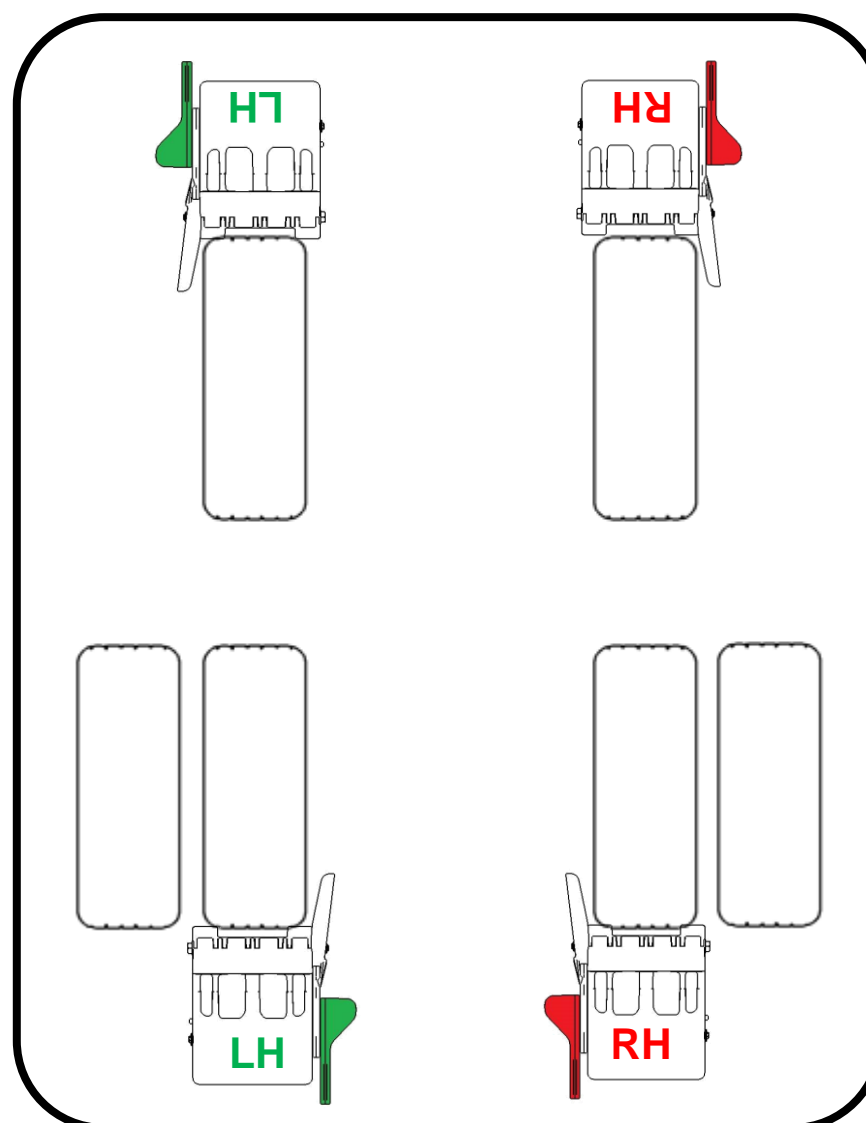

Extra Wide Vehicle Layout

Position chock outboard of the vehicle such that the lateral paddle is to the outside of the tire on the front end of the vehicle. For the rear, position the chock such that the lateral paddle is to the inside of the tires. Make sure lateral paddle has a gap of 3/4" or less to the tire sidewall.

Unloading Procedure

- 1. Remove from grating**
Unlock red / green pedal. Pull up and away to remove chock.

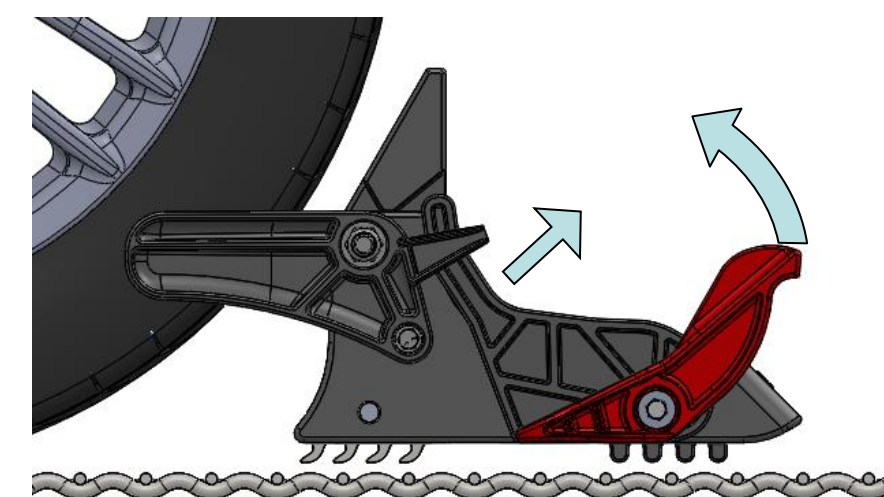

IF NECESSARY, use the Chock Removal Assist Lever to free a chock that has vehicle pressure against it

Unlock red / green pedal.

While holding the red / green pedal in the unlocked position, rotate the chock removal assist lever to pop the chock free.

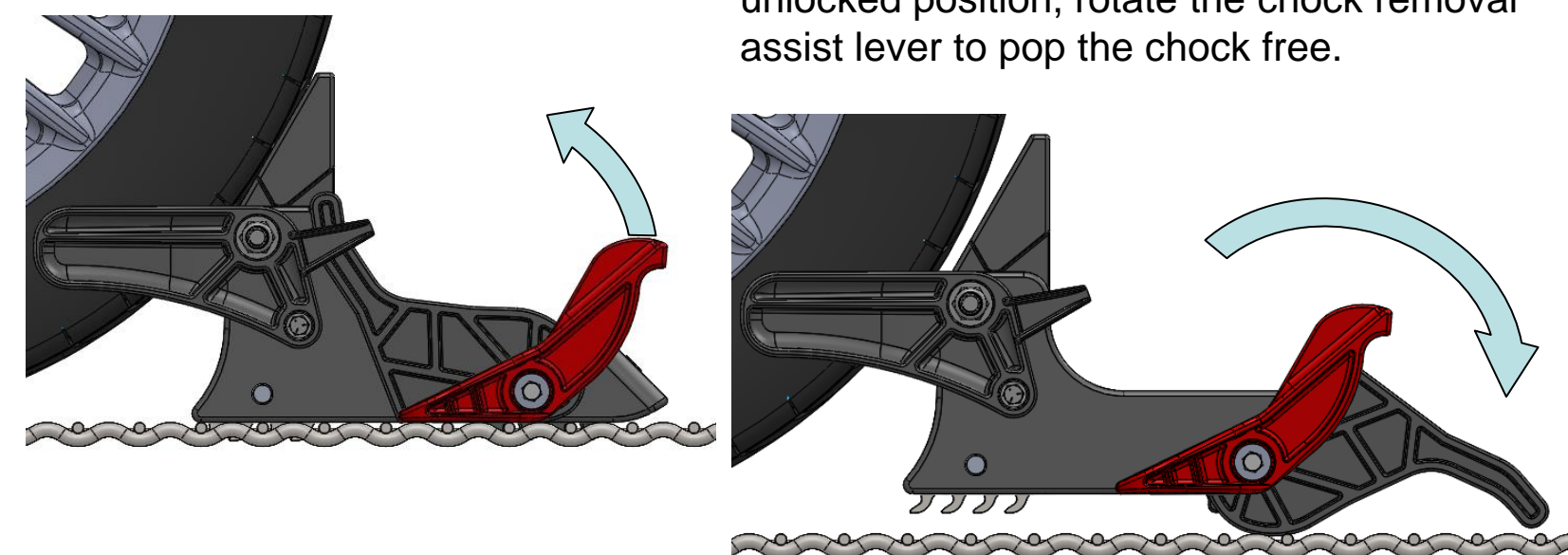

NOTE: Be sure to return the chock removal assist lever to its stowed position before storing.

2. Secure to storage pan

Rotate ramp for storage. Rotate red / green pedal and push chock against storage pan.

Maintain pressure and lock red / green pedal. Make sure orientation of chock is with lateral paddle pointing downward.

